

This research report is to be used for reference, research or record-keeping purposes only. Reports are not updated after their publication date and may not be relied on as a representation of Oil Sands Alliance.

GUIDELINES FOR TAILINGS DEPOSIT SAMPLING AND MEASURING TOOLS

REPORT

TO

CANADIAN OILSANDS INNOVATION ALLIANCE (COSIA)

Prepared By

COSIA GEOSTATISTICAL AND DEPOSIT SAMPLING WORKING GROUP

Monica Ansah-Sam, Thomas Binczyk, Chris Dobek, Africa Geremew, Chengmai Guo, Wayne Mimura,
Sidantha Weerakone

April 27, 2015

PAST AND PRESENT MEMBERS of the GSWG

Monica Ansah-Sam-Shell Canada

Thomas Binczyk - Canadian Natural Resources Limited

Guidelines for Tailings Deposit Sampling and Measuring Tools

Chris Dobek - Canadian Natural Resources Limited

Gennaro Esposito – Shell Canada

Africa Geremew - Alberta Energy Regulator (part time)

Chengmai Guo -Suncor Energy

*Colleen Jespersen - Suncor Energy

Stuart Nadeau - Imperial Oil Limited

Sidantha Weerakone - Imperial Oil Limited

**Bill Shaw - Total E&P Canada

Wayne Mimura - Syncrude Canada Ltd

*No longer with Suncor Energy

** No Longer with Total E&P

TABLE OF CONTENTS

1	Introduction.....	1
2	Issues not Addressed in Report.....	1
3	Fluid Fine Tailings Measurement Tools.....	2
3.1	Top of Pond.....	2
3.2	Mudline Interface.....	3
3.3	Bottom of Pond (Hard Bottom).....	4
4	Fluid Fine Tailings and Captured Fines Deposit Characterization	5
4.1	Fluid Fine Tailings Characterization	5
4.2	Captured Fines Deposit Characterization	6
4.2.1	CT (Consolidated/composite Tailings) / NST (Non-Segregated Tailings),	6
4.2.2	Beaches and Thickened Tailings.....	6
4.2.3	Thin Lift Deposit.....	7
4.2.3	Deep Lift Deposit.....	7
5	Field Sampling Tools.....	7
5.1	Tailings Behaviour Type (TBT)	8
5.2	Piston Sampler	9
5.2.1	Cyre Piston Sampler.....	9
5.2.2	Wireline Fluid Sampler.....	9
5.2.3	Hand Powered Suction Sampler	9
5.3	Sonic Sampling with an Thick Walled Piston Sampler	10
5.4	CRREL Barrel Sampler	10
5.5	Grab Samples	10
6	Sub-Sampling Procedures.....	10
6.1	Sub-sampling in the Laboratory.....	11
6.2	Sub-sampling in the Field	11
7	Conclusions.....	11
8	Recommendations	12
Appendix A: Specifications for Fluid Fine Tailings Interface Measurement Tools		1

Guidelines for Tailings Deposit Sampling and Measuring Tools

Appendix B: Verification of the Measured Mudline6

Appendix C: Validation of Bottom of Pond8

Appendix D: Comparison Between Piston Samplers.....14

Appendix E: Sub-Sampling Validation using Duplicate Samples15

Glossary A: Definitions and Acronyms19

1 INTRODUCTION

In 2009 the Alberta Energy Regulator (AER) implemented Directive 074 (D074). The main objective of the directive was to reduce the inventory of oilsands fluid fine tailings (FFT) across various leases of the mineable Athabasca oilsands. In response to the directive, operators have implemented a variety of site specific tailings measurement methods to monitor progress towards meeting the regulatory requirements.

The industry realised that such a variety of measurement and reporting methods could create differing approaches in estimating fluid tailings volumes as well as tailings performance. To introduce consistency in reporting, the Canadian Oil Sands Innovation Alliance (COSIA) was asked to evaluate the technical merits of various measurement techniques, and propose a set of industry recommended practices.

To meet this need the COSIA Tailings Environmental Priority Area (EPA) tasked the Tailings Measurement Steering Committee (TMSC) to produce these recommended practices. The scope developed into four areas of focus, including; Fines measurement, FFT Volume determination, Deposit Characterization, Sampling and Geostatistics.

This report provides the results of the Geostatistical and Sampling working group, and is provided as a final submission to the TMSC. Three separate reports were produced; “A Geostatistical Study to Quantify Uncertainty in Tailings Fines Content as a Function of Data Spacing” and “Workflow and Software Guide for Constructing a Three Dimensional Geostatistical Model of a Tailings Deposit for the Purpose of Conducting a Geostatistical Resampling Study”, “Guideline for Tailings Deposit Sampling and Measuring Tools”. For the purposes of continuity the first two reports were combined as one report. The first report was written by K. Daniel Khan and Jared Deutsch with Clayton V. Deutsch which addresses the spatial variation for typical oil sands tailings deposits.

2 ISSUES NOT ADDRESSED IN REPORT

A recommended spacing interval for most of the sampling methods was not determined. This was due to the inherent variability in each tailings deposit, the age of the deposit, the type of stream reporting to the tailings pond, and the size and shape of the deposit. This decision was supported by the work done by K. Daniel Khan and Jared Deutsch with Clayton V. Deutsch, as discussed in their report “A Geostatistical Study to Quantify Uncertainty in Tailings Fines Content as a Function of Data Spacing”. The sampling locations and intervals will need to be determined on a case by case basis using the engineer’s experience with the deposit, and level of confidence in the variability of the deposit.

A standard guideline for strength measurement to characterize the deposit is not addressed in this report. Please refer to the report by the Deposit Characterization sub-committee titled “Measuring undrained shear strength for compliance with Directive 074”.

3 FLUID FINE TAILINGS MEASUREMENT TOOLS

In order to obtain representative data that will allow for the determination of the different components for the fluid fine tailings measurement, a number of tools and methods are recommended that depend on the characteristics and type of the tailings pond being analyzed. The components that need to be measured for reporting the fluid tailings inventory are the top of pond, the mudline and the bottom of pond, sometimes called the hard bottom. The recommended tools, spacing and verification are shown in Table 1 below. A description of each component is described following this table and is referenced in the last column. A detailed description of the individual sampling tools is provided in Section 5 of this report.

Table 1: Fluid Fines Tailings Measurement Tools

Fluid Fine Tailings Measurement Tools				
	Tools	Spacing	Verification	Section
Top of Pond (typically water)	<ul style="list-style-type: none"> <input type="checkbox"/> RTK survey quality equipment or equivalent 	<ul style="list-style-type: none"> • No fixed spacing but interval of readings based on fluctuation of pond elevation • Readings should also be concurrent with the sampling / testing program 	<ul style="list-style-type: none"> <input type="checkbox"/> Survey equipment should have an accuracy of +/- 25mm 	3.1
Mudline (water and fluid fine tailings interface)	<ul style="list-style-type: none"> <input type="checkbox"/> Sonar or Density Plate 	<ul style="list-style-type: none"> <input type="checkbox"/> Grid spacing may vary depending on pond geometry and composition. 	<ul style="list-style-type: none"> <input type="checkbox"/> Validation by fixed interval sampling 	3.2
Bottom of Pond (Hard bottom)	<ul style="list-style-type: none"> • Original ground prior to tailings placement surveyed by LiDAR aerial survey or equivalent • Drop sounding tool (CT09) • Cone Penetration Testing (CPT) if deposit does not allow accurate CT09 measurements 	<ul style="list-style-type: none"> • Aerial survey should have an accuracy of +/- 15 cm. Grid spacing is dependent on footprint of tailings area and undulations. • The drop sounding tool is typically done on a grid. • No fixed grid spacing; depends on the pond geometry and composition. 	<ul style="list-style-type: none"> • Standard QA for survey data • Drop sounding tool verified by occasional CPT's • CPT interpretation must be by experienced personnel 	3.3

3.1 TOP OF POND

To determine the top surface of a tailings pond that is typically water, survey equipment or an equivalent, must be used that should have an accuracy of +/- 25mm.

The surveying equipment requires no fixed spacing due to the minimal variability of the elevation of the pond surface. The only requirement is that the location should be shielded from waves or the variability due to waves must be accounted for. If the measurement is taken from a boat or equivalent, the variability due to the wake and draft of the boat must be considered.

The top of pond survey needs to be concurrent with the sampling / measuring program to provide accuracy in the measurement as the pond elevation may vary throughout the sampling / measuring program.

3.2 MUDLINE INTERFACE

The mudline interface is defined as the boundary between the water and top of the underlying fluid fine tailings. The mudline interface in a tailings pond can be measured using either a 200 kHz sonar or a density plate (details described in Appendix A).

The sonar utilizes a 200 kHz sound pulse directed downwards to measure the depth of the mudline which is the interface between the fluid fine tailings and the overlying recycle water. The sonar mudline is detected by reflected pulses of sound energy with the time for the reflection recorded via a transducer. This time is then multiplied by the speed of sound in water to determine the distance the sound wave travelled. Depending on the system a near continuous depth measurement can be taken on gridlines (often at 200m by 200m) that can later be used to develop a mudline surface. Standardized guidelines for the sonar are included in Appendix A.

A density plate is a thin plate that has symmetrical holes placed on it that hold weights. The weights ensure that the correct density is obtained for the plate. Thin wires are attached to each corner of the plate and meet in the middle of the plate at a specified height. At the point where the wires attach, a depth measuring tape/wire is attached, with the zero point of the tape measure referenced to the mid thickness of the plate.

The plate is placed flat in the water at the desired location and is allowed to sink on its own weight until it stops. The plate is then raised slightly and allowed to fall again. The plate should fall within 1cm of the first stopping place; otherwise the test will need to be re-conducted. The point where the plate stops has a specific density and is defined as the mud line interface. Standardized guidelines for the density plate are included in Appendix A.

Validation of the mudline interface measured:

The results obtained from the sonar or density plate testing must be validated by obtaining samples using a fixed interval sampler and analyzed for solids content. The validation sampling procedure utilizes a fixed interval sampler capable of sampling the fluid at 10 cm increments for a distance of 0.5m above and below the measured mudline.

The mudline is verified by determining that the average change in percent solids is greater or equal to 5 percent that occurs over a 10 cm interval. The mudline measured by the density plate or the sonar ranges from 0.14 to 19.2 percent solids content (See Appendix B).

A minimum of three fixed interval sampling locations are required for each pond at locations based on engineering judgment to best represent the mudline interface measured by the sonar or density plate.

Mudline interface measurement spacing:

The size, type and variability of the tailings deposit will determine the measurement spacing and location. Typical grid spacing for the sonar or the density plate is less than 200m by 200m.

3.3 BOTTOM OF POND (HARD BOTTOM)

The bottom of pond or hard bottom is the transition between fluid fine tailings overlying the original ground surface or overlying the infilled surface of sand or captured fines (i.e. in final location). An infilled surface can be a sharp transition, for example, where FFT meets a sand beach, or more gradual such as those found in CT deposits. To determine the original surface, an Aerial or LiDAR survey of the ground surface or pit floor must be completed prior to filling. To determine the bottom of pond overlying an infilled surface, a drop sounding tool or cone penetration test (CPT) must be used. A combination of these two measurements is often required to model the bottom of pond.

The bottom of pond is determined as the point of refusal with a drop sounding tool, and periodically validated by CPT at select locations. A drop sounding tool currently used in the industry is the CT09. An equivalent drop sounding tool must meet the specifications described in Appendix A. The depth measured must be corrected for inclination overall and where it stops. The measurement by the drop sounding tool is much faster than the measurement with the CPT so more locations can be measured than is possible with the CPT. However, the drop sounding tool may not accurately measure the bottom of pond due to increased resistance from denser MFT, bitumen or organics and if this occurs the CPT must be used. Periodic CPT is required at select locations to validate the drop sounding tool measured depth.

The CPT refers to both the full flow ball and cone penetrometer. More details on these tools are discussed in the report prepared by the Deposit Characterization sub-committee titled “Measuring undrained shear strength for compliance with Directive 074”.

Validation of the bottom of pond or hard bottom:

To validate that the drop sounding tool is accurately measuring the true bottom of pond, some select CPTs are required to validate the measurements with optional geotechnical testing of samples. Bottom of pond measurements with the drop sounding tool CT09 and the CPT show good correlations and are shown in Appendix C.

The interpretation of the CPT data must be done by trained and experienced personnel as there are numerous considerations that must be taken into account to interpret the bottom of pond. Most bottom of pond interpretations can be made by analyzing the tip resistance, however, other data may be available that can assist in the interpretation such as dynamic pore pressure, passive gamma and tailings behavior type (TBT). Other considerations would be the history of deposition and knowledge of the type of tailings in the deposit or pond.

No sampling is required for the determination of the bottom of pond; however sampling can sometimes help to further verify the bottom of pond by characterizing the material. Sampling is often required for other purposes, such as to gather geotechnical properties and composition characterization of the fluid fine tailings.

Bottom of pond measurement spacing:

The size and variability of the tailings deposit will determine the measurement spacing and location. Typically, the CT09 is conducted on a grid spacing between 100m to 200m. Validation of the CT09 depths must be periodically validated using the CPT. There is no fixed grid spacing for the CPT; depends on the geometry and composition of the pond.

4 FLUID FINE TAILINGS AND CAPTURED FINES DEPOSIT CHARACTERIZATION

The recommended tools and spacing required to characterize and sample the various types of tailings deposits is described in this section and listed in Table 2. A more detailed description of the tailings deposits with recommended sampling tools, spacing and verification is described following this table and is referenced in the last column. A detailed description of the individual sampling tools is provided in Section 5 of this report.

Table 2: Fluid Fine Tailings and Captured Fines Deposit Characterization

Fluid Fine Tailings and Captured Fines Deposit Characterization				
	Sampling Tools	Spacing	Verification	Section
Fluid Fine Tailings	<ul style="list-style-type: none"> • Wireline fluid sampler, Hand piston sampler • Cyre piston sampler • Hand powered suction sampler • Cone Penetration Test (CPT) with Tailings Behavior Type (TBT) 	□ The spacing and number of test locations will be based on the engineering judgment that considers the type and size of deposit as well as homogeneity.	□ Sub-sampling can be done in the field or in the laboratory. Periodic duplicate samples must be taken to QA the subsampling accuracy	4.1
CT, NST, or TT	<ul style="list-style-type: none"> • Non-vibratory piston or Sonic piston sampler • Cyre piston sampler • Cone Penetration Test (CPT) with Tailings Behavior Type (TBT) 			4.2.1
Thin Lift Deposit	<ul style="list-style-type: none"> • Non-vibratory piston or Sonic piston sampler • Cyre piston sampler • Grab sample • CRREL barrel sampler 			4.2.2
Deep Lift Deposit	<ul style="list-style-type: none"> • Non-vibratory piston or Sonic piston sampler • Cyre piston sampler • Cone Penetration Test (CPT) with Tailings Behavior Type (TBT) 			4.2.3

4.1 FLUID FINE TAILINGS CHARACTERIZATION

In order to characterize the fines and solids content of the fluid fine tailings present in a tailings pond, a number of tools are recommended to obtain samples. The Cyre or piston sampler, the hand powered suction sampler and the wireline fluid sampler are presently used within the industry.

Guidelines for Tailings Deposit Sampling and Measuring Tools

Only a limited amount of data is available to compare the results from the various tools but the limited data suggests there is a good comparison between the tools but further study is recommended. Some comparisons are shown in Appendix D.

The use of the Tailings Behavior Type (TBT) interpreted from the Gamma Cone Penetration test with pore pressure measurement (GCPTu) can be used for determining the fines and solids content in place. TBT can be used in certain situations to supplement conventional sampling of the fluid fine tailings. Comparison of the interpreted TBT results to laboratory sample analysis must be done to validate the procedure. In addition, periodic samples to ensure consistency and accuracy must be taken.

Sampling locations and intervals will vary by deposit because they depend on the size and variability of the tailings deposit. The uncertainty in the deposit can sometimes be quantified with Geostatistics. The sampling locations and intervals will need to be determined on a case by case basis by a qualified engineer.

4.2 CAPTURED FINES DEPOSIT CHARACTERIZATION

Similar to the fluid fine tailings characterization, to characterize the different types of captured fines deposits the equipment and procedures used are dependent on the type of deposit. The different types of deposits that need to be analyzed to determine their composition and characterization are the tailings beaches (including coarse, flotation, and froth treatment tailings), composite or consolidated tailings deposits (CT), which is also sometimes referred to as nonsegregating tailings (NST), thin or deep lift deposits (for example, centrifuged, atmospheric fines drying and thickened tailings), or captured fines below the bottom of pond (hard bottom), and any new solid deposit type that may be developed in the future.

4.2.1 CT (CONSOLIDATED/COMPOSITE TAILINGS) / NST (NON-SEGREGATED TAILINGS), BEACHES AND THICKENED TAILINGS

Characterization by obtaining samples of the CT/NST deposits and coarse tailings, floatation tailings and other beaches must be sampled using a piston or sonic type sampler, or an approved equivalent.

The sampling and characterization locations and spacing required to obtain a representative determination of the deposit are highly dependent on the pond history, deposit geometry and composition. The sampling locations and spacing will need to be determined on a case by case basis using the engineer's judgment and level of confidence with Geostatistics, if required, and the variability of the deposit.

Sub-sampling of the samples collected of captured fines deposit can be conducted either in the field or in the lab and periodic duplicate QA samples must be collected and analysed to ensure the subsampling procedure provides consistent and accurate representative samples.

The use of the Tailings Behavior Type (TBT) interpreted from the Gamma Cone Penetration test with pore pressure measurement (GCPTu) can be used for determining the fines and solids content

in place. TBT can be used in certain situations to supplement conventional sampling of the fluid fine tailings. Verification of the interpreted results from laboratory sample results must be done to validate the procedure and periodic validation samples to ensure consistency and accuracy.

4.2.2 THIN LIFT DEPOSIT

A thin lift deposit is defined as a deposit of tailings that has individual layers of treated tailings that are typically less than 2m in height. In order to characterize a thin lift deposit, grab samples, piston type samplers or sonic samplers are acceptable tools to use to collect representative samples.

The sampling locations and intervals needed in order to get a representative determination of a thin lift deposit composition are highly dependent on the deposit geometry, composition and geostatistical tool used. The sampling locations and intervals will need to be determined on a case by case basis using the engineer's experience and judgment and level of confidence in the variability of the deposit.

Further sub-sampling of a thin lift deposit can be done either in the field or in the lab with periodic duplicate QA samples to ensure the sub-sampling procedure provides consistent and accurate representative samples.

4.2.3 DEEP LIFT DEPOSIT

A deep lift deposit is defined as a deposit of tailings greater than 2m in height. Some examples of deep lift deposits are the accelerated dewatering deposit and the centrifuged product or cake. Dewatering of the tailings occurs mainly through self-weight consolidation. In order to characterize a deep lift deposit a piston or sonic type sampler are acceptable tools to use.

The sampling locations and intervals needed in order to get a representative determination of a deep lift deposit composition are highly dependent on the deposit geometry, composition and geostatistical tool used. The sampling locations and intervals will need to be determined on a case by case basis using the engineer's judgment and level of confidence in the variability of the deposit.

Further sub-sampling of a deep lift deposit can be done either in the field or in the lab with periodic duplicate QA samples to ensure the sub-sampling procedure provides consistent and accurate representative samples.

5 FIELD SAMPLING TOOLS

The recommended standard field sampling tools used to either sample or characterize the fluid fine tailings and captured fines deposit and listed in this section and listed in Table 3. A description of each tool is described following this table and is referenced in the last column.

Table 3: Field Sampling Tools

Tools	Verification	Section
--------------	---------------------	----------------

Guidelines for Tailings Deposit Sampling and Measuring Tools

Tailings Behaviour Type (TBT)	<input type="checkbox"/> Tailings Behaviour Type (TBT) interpretation from GCPTu	<ul style="list-style-type: none"> • Interpretation algorithm must be validated prior to use • Periodic samples required to verify the algorithm is consistent and relevant 	5.1
Cyre Piston Sampler	<input type="checkbox"/> Non-vibratory pneumatic piston sampler	<input type="checkbox"/> Periodic duplicate samples for QA/QC	5.2.1
Wireline fluid Piston Sampler	<input type="checkbox"/> Non-vibratory piston sampler used for fluid fine tailings		5.2.2
Hand Powered Suction Sampler	<input type="checkbox"/> Non-vibratory hand powered suction sampler		5.2.3
Sonic Thick Walled Piston Sampler	<input type="checkbox"/> Vibratory energy to advance a thick walled piston sampler		5.3
CRREL barrel sampler	<input type="checkbox"/> Used to collect a frozen core of soil and provide access to the unfrozen deposit below		5.4
Grab samples	<input type="checkbox"/> Manually collected samples taken by hand		5.5

5.1 TAILINGS BEHAVIOUR TYPE (TBT)

The Cone Penetration Test (CPT) can be used to determine the shear strength of a deposit, but it is not capable of obtaining samples. The piezo cone (CPTu) is capable of measuring dynamic pore pressure, pore pressure dissipation rates and in-situ pore pressure. A module that measures the passive gamma radiation (bulk natural radiation emitted from soils) can be added to the CPT. Empirical relationships can be made between the in-situ and laboratory measurements using the passive gamma cone penetration test with pore pressure measurements (GCPTu). The empirical relationships developed are the fines content (5 μ m and 44 μ m) and solids content.

Using TBT data to supplement conventional sampling data gives a much higher spacial density of sample locations and can measure the tailings in-situ without the need for sampling. Prior to using TBT, the interpretation algorithm must be validated with laboratory analysis of samples obtained

by conventional sampling procedures. Periodic samples are required to be collected, analysed and compared to the TBT results to verify that the algorithm is consistent and relevant.

5.2 PISTON SAMPLER

Various types of piston samplers can be used to collect fluid or solid tailings and usually collect a “core” type sample. There are a number of piston samplers that are acceptable to use and are described below. All samplers collect a sample that has a degree of disturbance from its in-place state, with an increasing amount of sample disturbance the softer or more fluid like the deposit is.

5.2.1 CYRE PISTON SAMPLER

A Cyre sampler is a pneumatically actuated piston inside a small diameter sample barrel that does not utilize vibration to advance the sampler. The Cyre sampler is typically used to collect samples of fluid fine tailings and soft captured fines deposits.

Prior to collecting a sample with the Cyre sampler, it must be cleaned and the piston must be fully extended so that it is flush with the leading edge of the core barrel. The chamber behind the piston must be pressurized (typically with nitrogen) to ensure that the piston remains in place. The sampler is then pushed into the deposit to the target depth. Once the sampler is at the target depth, the inner rod is kept at a fixed elevation as the cone rods advance the outer cylinder, collecting a sample within.

Once the sample is collected it stays in the barrel during extraction through passive suction in soft deposits and through friction in more solid deposits. The amount of disturbance of the sample depends on how fluid or solid the deposit is, with a lesser degree of disturbance for the later.

5.2.2 WIRELINE FLUID SAMPLER

A wireline fluid sampler is a piston-type fluid sampler typically used to collect samples of fluid fine tailings. No vibration is used to advance the sampler.

The piston is held in a closed position with pressure from nitrogen gas during deployment to the target depth. Once the sampler is at the target depth, the gas supply is turned off and the hydrostatic pressure of the fluid forces the piston to retract filling the sample chamber with fluid. A wireline fluid sampler collects a discreet volume of sample (not a core) which is disturbed. The sampler must be able to retrieve the sample to the surface with a full or near-full recovery.

5.2.3 HAND POWERED SUCTION SAMPLER

A hand powered suction sampler is a hand actuated syringe type sampler that is used primarily to collect samples from shallow fluid fine tailings deposits that cannot be collected through other means. It collects a discreet volume of sample (not a core) which also has some disturbance.

The sampler is lowered to depth by hand with the piston fully depressed. Once at depth, the sampler barrel is held in place while the piston is retracted by hand, collecting the sample. No vibration is used to advance the sampler.

5.3 SONIC SAMPLING WITH AN THICK WALLED PISTON SAMPLER

The key difference between a sonic sampler and the samplers mentioned above is the use of vibratory energy in the drill string in order to advance the sampler. Sonic samplers collect “core” type samples. A sonic piston sampler is not typically used for fluid tailings but its main use is for tailings deposits ranging from soft fine tailings to coarse beach and cell sand deposits. A low frequency and energy vibration is recommended to minimize the liquefiable zone around the sampler and disturbance of the sample.

Various sonic samplers and sonic drilling methods are available. In general, before beginning retrieval the sample head is filled with water, causing the piston to close the sample chamber. The water valve is locked and the sampler and attached drill rods are then rotated down to just above the desired sample interval. Vibrations are induced in the drill string which liquefies a thin layer around the rods and sampler allowing the sampler to be pushed through the desired interval with less friction. The thick walled piston sampler (similar to the AquaLock piston sampler) uses water pressure to hold the piston in the closed position until the target depth is reached. The water pressure is released as the sampler is advanced and then locked again to create passive suction to retain the sample.

There is still reliability issues related to the liquefaction and the potential to lose water during sampling, and therefore the measured solids content could be affected. The AquaLock piston sampler currently being used visually appears to be capturing the water. This is one area where further testing and research is needed. Presently, the sonic sampler with the AquaLock type thick walled piston sampler is the most efficient production sampler available for oil sands tailings deposits, especially when the deposits are deep, soft or layered or a combination.

5.4 CRREL BARREL SAMPLER

Some thin lift captured fines deposits can best be trafficked in the winter when there is a frozen cap. A CRREL barrel sampler (Cold Regions Research and Engineering Laboratory) was developed to collect a core of frozen soil (or ice) in a permafrost zones. The soil core can be sent to the laboratory for characterizing the fines content. The resulting core hole can then be used to further sample the unfrozen deposit below or measure other properties such as strength by using CPT or VST.

5.5 GRAB SAMPLES

Grab samples of the tailings deposit are manually taken by hand. Grab samples are taken of deposits that are not accessible with testing and sampling equipment and are shallow in thickness. Engineering judgment and procedures, which have been verified with duplicate samples, is required to properly extract a representative sample.

6 SUB-SAMPLING PROCEDURES

Sub-sampling into a number of smaller representative samples is required for further characterization tests, such as bitumen, solids and fines content or other chemical tests. The subsampling can be done in the field or in the laboratory. Sub-sampling in the field may be required

due to the logistics of transporting and storing the large number of samples that are collected for a large tailings deposit.

Periodic duplicate sub-samples must be taken to ensure the quality assurance of the procedure is acceptable. There is limited data to verify the procedures however; the duplicate sample analyses should be compared to ensure that the sub-samples are representative and accurate. A comparison of some duplicate laboratory sub-samples is shown in Appendix E. At the present time, there is no data for comparing duplicate sub-samples taken in the field.

The following are the proposed standard procedures to use for sub-sampling in the laboratory or in the field.

6.1 SUB-SAMPLING IN THE LABORATORY

- Samples are received in containers up to a 5 litre pail.
- Sample is homogenized in the lab using an overhead mixing motor attached to an impellor for approximately 1 minute, increasing speed from low to high, or placed in an industrial shaker for 5 minutes.
- A portion of the material is then removed with a scoop or ladle and placed in the subsample container when using impellor. The original sample is re-blended and a new subsample is removed with the scoop or ladle.
- When using the industrial shaker, the pail lid is removed and the sample is immediately stirred with a ladle prior to sub-sampling into a 500 ml jar. Stirring should still occur in between scoops.
- The process is repeated until all sub-samples have been collected.
- Periodic samples to be taken to verify sub-sampling repeatability.

6.2 SUB-SAMPLING IN THE FIELD

- A solid or fluid sample is collected and put it into a large mixing bowl.
- The sample is homogenized by hand mixing and then sub-sampled into a 250ml bottle with the remaining disposed.
- The process is repeated until all sub-samples have been collected.
- Periodic sub-samples need to be taken to verify sub-sampling repeatability.

7 CONCLUSIONS

The following are the main conclusions:

- This proposed COSIA technical guideline will standardize industry practices for collecting samples in fluid fine tailings and captured fines deposits, and standardize sub-sampling procedures.
- The guideline identifies a standard sampler to be used for different tailings deposits recognizing the need to sample the deposits as efficiently as possible and doing so in a safe manner.

Guidelines for Tailings Deposit Sampling and Measuring Tools

- The volume of fluid fine tailings is measured by determining the top of pond, mudline and bottom of pond or hard bottom. Various tools are recommended to standardize the measurements as well as verification methods.
- Fluid fine tailings and various captured fines deposits are listed with the recommended sampling tools to standardize the measurement for each deposit type for composition characterization.
- Recommended sampling tools are listed and described to standardize the type of tools. The sampling tool required depends on the type of deposit, including considerations for depth and consistency.
- Interpretation of the data must be done by experienced personnel to correctly identify errors or anomalies in the readings.
- Field and laboratory sub-sampling procedures are recommended to standardize the procedures for representative and comparable results.
- Spacing horizontally and vertical sampling intervals of test locations are dependent on the consistency (variability such as layering) and type of tailings deposit being investigated. Oil sand Operators must consider these coupled with engineering judgment and experience.

8 RECOMMENDATIONS

The following are some recommendations for further study:

- The sonic sampler with the use of an AquaLock type piston sampler is currently the only sampler that can be used in soft homogeneous or layered tailings deposits. There is some concern that the vibration may be affecting the water or fines content of the sample. This is an area that can be studied further.
- Some of the comparisons are based on limited data so as more pond data is collected, the comparisons can be revisited.

APPENDIX A: SPECIFICATIONS FOR FLUID FINE TAILINGS INTERFACE MEASUREMENT TOOLS

The interface between the clear water zone and the fluid fine tailings termed the mudline can be measured using the sonar or density plate. The bottom of pond can be measured with a drop sounding tool or the cone penetration test. The currently used drop sounding tool is named the CT09. The drop sounding tool named the AK97 is not described in this document mainly because it is no longer being used by industry but has been used in the past.

The specifications for the sonar, density plate and the CT09 drop sounding tool are described in this section. Equivalent tools must meet these specifications and be validated with sufficient data for approval for use.

Sonar Mudline Measurement

The sonar utilizes a 200 kHz sound pulse directed downwards to measure the depth of the mudline which is the interface between the fluid fine tailings and the overlying recycle water. The sonar mudline is detected by reflected pulses of sound energy with the time for the reflection recorded via a transducer. This time is then multiplied by the speed of sound in water to determine the distance the sound wave travelled. Depending on the system a near continuous depth measurement can be taken on gridlines that can later be used to develop a mudline surface.

The sonar depth measurement coordinated with the use of a GPS system is required and the following information must be recorded:

- Depth of the mudline corrected for the depth of the sonar transducer
- XY location of the sonar measurement
- Pond surface elevation

The sonar transducer must be adjusted to ensure the sound pulse is projecting vertically downwards. The transducer keel offset distance can change depending on wave action and boat speed that must be considered and accounted for in the measurements.

The mudline surface is typically a sharp transition from low to high solids content in oil sand tailings ponds. If the mudline transition is not sharp but occurs over a larger zone, then additional sample collection using a fixed interval sampler is required.

Validation of the mudline must be verified by collecting and analyzing samples collected from a fixed interval sampler from at least 3 locations. The locations for these fixed interval samples are based on engineers judgment.

Density Plate Mudline Measurement

The mudline density plate shown below in Figure 1 is a plastic plate. It is used to detect the mudline which is the interface between the fluid fine tailings and the overlying recycle water. It is approximately 3600 cm² with a thickness of 25 mm. The plate has symmetrically placed holes in it that are used to hold stainless steel bolts and nuts. These metal pieces are used to ballast the plate so that it has an equivalent density of approximately 5% solids content at room temperature. The plate has a thin stainless steel wire attached to each corner. These wires meet in the middle of the plate at a height of about 20 cm. This point is where the depth measuring wire is attached, with the

Guidelines for Tailings Deposit Sampling and Measuring Tools

zero point of the wire measure referenced to the mid thickness of the plate. The wire is marked at 0.25m intervals for measurement reference.

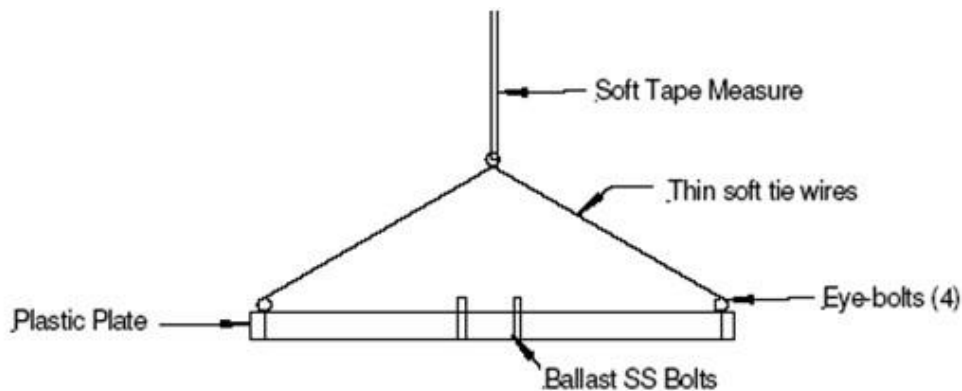

Figure 1: Density Plate Schematic

The boat is anchored at the desired location on the pond and allowed to position itself from effects of current and wind which normally takes 2-3 minutes. Movement that causes the cable attached to the density plate to deviate from vertical will affect the accuracy of the measurement. This effect is compounded at greater depths.

The plate is placed in the water such that it is flat and allowed to sink on its own weight until it stops. The plate is slowly raised 1-2 centimetres and allowed to fall again. The second value should be within 1 centimetre of the first. If the second value deviates more than 1 centimetre from the initial, the test shall be re-conducted. A tape measure is used to establish the distance between the water surface to the nearest marker on the measurement wire. This point is where the water and solids have a combined density of 5% solids content.

The surface of the plate and the measuring tape/wire must be cleaned after every run to prevent the collection of bitumen and sand, which will adversely affect the density. Accumulated debris or bitumen on the plate can skew the density measurement and affect performance. Areas with surface accumulation of bitumen are either avoided or the bitumen cleared away before use.

Crimps in the measurement wire may occur over time. Severe crimps/kinks in the cable will affect the measurement.

Calibration of the plate should be performed at least once a year. For calibration, the plate is suspended in a salt water solution containing 50 grams of salt per litre of water. For sensitivity, the plate will float in 55 g/L and sink in 45g/L. Calibration begins with a solution of 20 L of water containing 800 g of salt. Salt is added until the plate reacts. The calibration is performed with wires attached, imitating field testing methods. Ballast in the form of stainless steel nuts, bolts, and screws is added or removed until the plate is fully submerged and floating freely in the solution.

Validation of the mudline must be verified by collecting and analyzing samples collected from a fixed interval sampler from at least 3 locations. The locations for these fixed interval samples should be based on engineers judgment.

Drop Sounding Tool (CT09 or Equivalent) for Bottom of Pond Measurement

The drop sounding tool (CT09 presently used in the industry) is the recommended tool to measure the bottom of pond or hard bottom. The dimensions of the drop sounding tool are shown in Figure 2. Other useful information that can be gathered but not a requirement is tip resistance, pore pressure and inclination. The tip resistance is for reference only as any interpretations for shear strength has not been corrected for temperature.

At each sounding location, the following data is recorded:

- Pre-test GPS and at-refusal GPS coordinates
 - Triangulate for total drift
 - Maximum total drift for any location is 5.0% of the measured depth
 - Calculated as Measured Depth x 5.0%
 - This limits the total Maximum Error to 4.8% of the actual depth
- Data acquisition systems record depth, time, and tool measurement data continuously during deployment, and store the data

The tool is deployed using a winch line from a variety of platforms. Once on location, the tool is deployed on the winch from the pond surface as a free drop to the maximum speed of the winch or at the maximum speed of the tool as it passes through the tailings, whichever is slower. If the deposit becomes thick the drop speed will slow, and the winch speed should be adjusted to follow by the operator. When the tool stops moving, defined as less than 5cm over a 30 second period, the test is terminated and the tool is retrieved to the surface for data downloading.

If the tool stops due to factors other than an actual hard bottom, then it does not necessarily reflect the desired bottom of pond surface. This is typical in older ponds with high solids content and high bitumen areas or floating muskeg mats. Several drops in the same location may punch through the obstruction, but this may not always be successful. If this condition occurs, then CPT's must be used in lieu of the drop sounding tool.

Design schematic of one of these tools is included as the accepted general design for oil sands pond bottom determination.

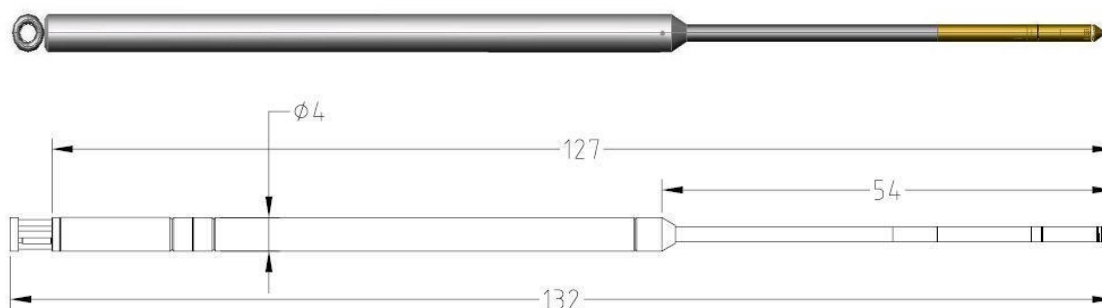

Figure 2: Drop sounding schematic - dimensions in inches

General Equipment Specifications for Drop Sounding Tool

- 300lb/ 136kg total weight / mass
- 132 inches long
- 4" diameter weighted section decreasing to 1.75" for last 54"
- Deployed on a wireline winch at up to 1.0m/s, velocity of deployment depends on winch speed and material it is passing through
- Piezocone penetrometer capable of measuring inclination, pore pressure (U2), and tip resistance forms the end of the tool (not a mandatory requirement but beneficial).

Deployment Equipment

- Boat, barge, amphibious platform
- Capable of holding position during testing within a reasonable margin – preference is for fixed position during testing.
- On-board GPS to determine test location and measure drift during the test
 - a. Position and drift must be recorded
- Deployment winch with calibrated depth measurement device

Data Recording and Reporting

- All of the parameters below should be recorded vs depth :
 - a. Tip resistance
 - b. Dynamic pore pressure (not a basic requirement but beneficial)
 - c. Shear strength (not a basic requirement but beneficial)
 - d. Inclination
 - e. Depth
 - f. Interpreted “hard bottom” – either refusal or above refusal based on interpretation of the recorded parameters
- Typically this data is used to produce digital surfaces, which are utilised to calculate total volumes of fluid tailings through the use of spatial analysis and modelling software.

APPENDIX B: VERIFICATION OF THE MEASURED MUDLINE

The interface between the clearer water zone and the fluid fine tailings or mudline elevation is measured using the sonar or the density plate. Validation of this mudline is required by taking samples using a fixed interval sampler capable of taking samples at the mudline and 5 samples every 10 cm for a distance of 0.5 above and below the measured mudline.

Guidelines for Tailings Deposit Sampling and Measuring Tools

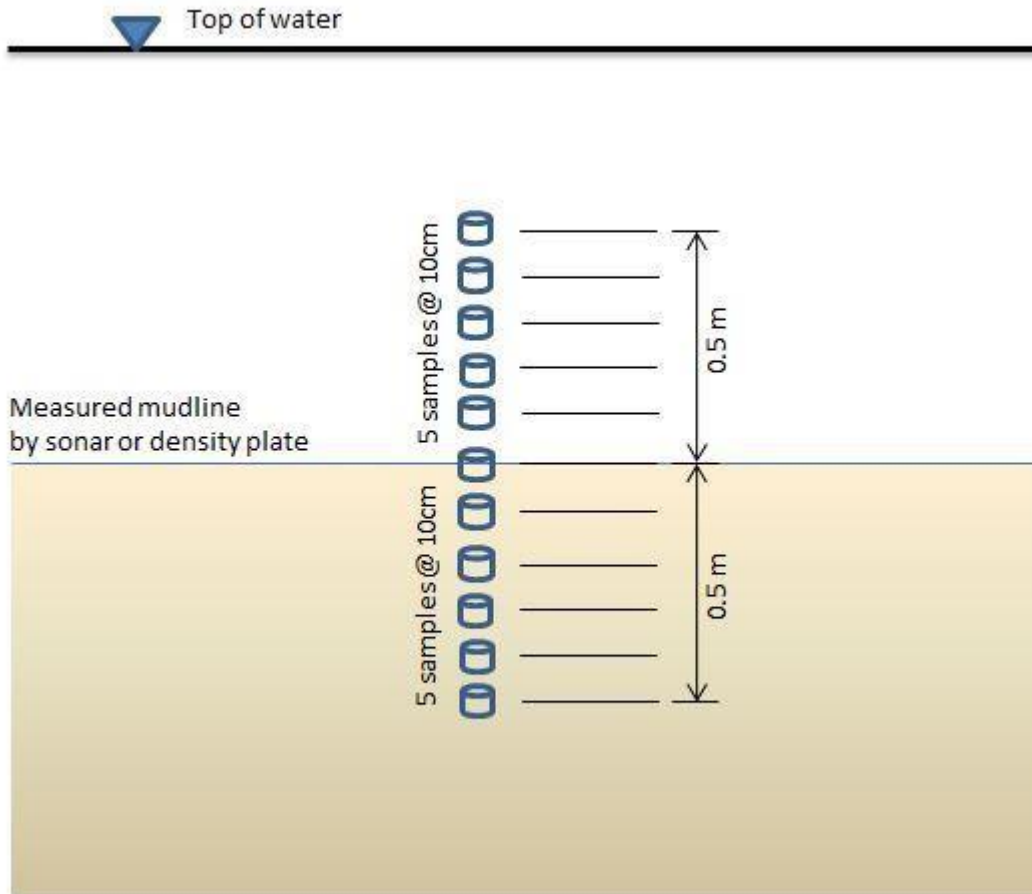

The measured mudline elevation is validated when the change in percent solids is equal to or more than 5% over a distance of 10 cm. The mudline validated by fixed interval sampling of seven ponds from four different Operators is plotted below. The mudline measured by the density plate or the sonar ranges from 0.14 to 19.2 percent solids content. At the mudline interface, the solids content increases over a narrow depth, and this sharp change in solids content is what the sonar reflects off of and not a specific solids content. The median value of the distribution is 5.7% solids content change per 10cm interval.

Guidelines for Tailings Deposit Sampling and Measuring Tools

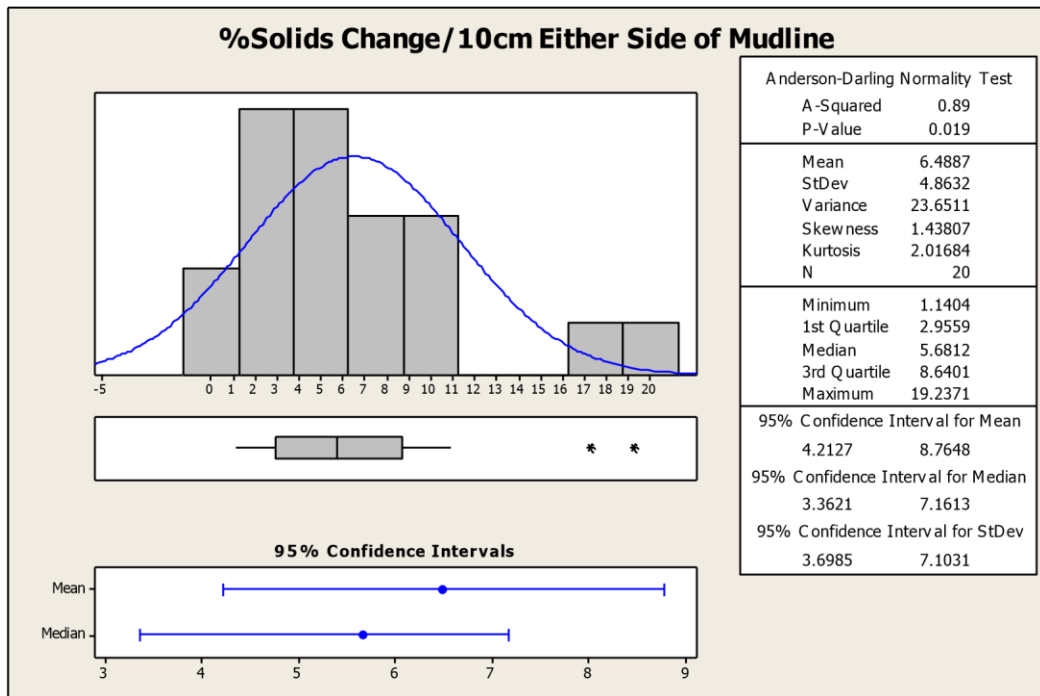
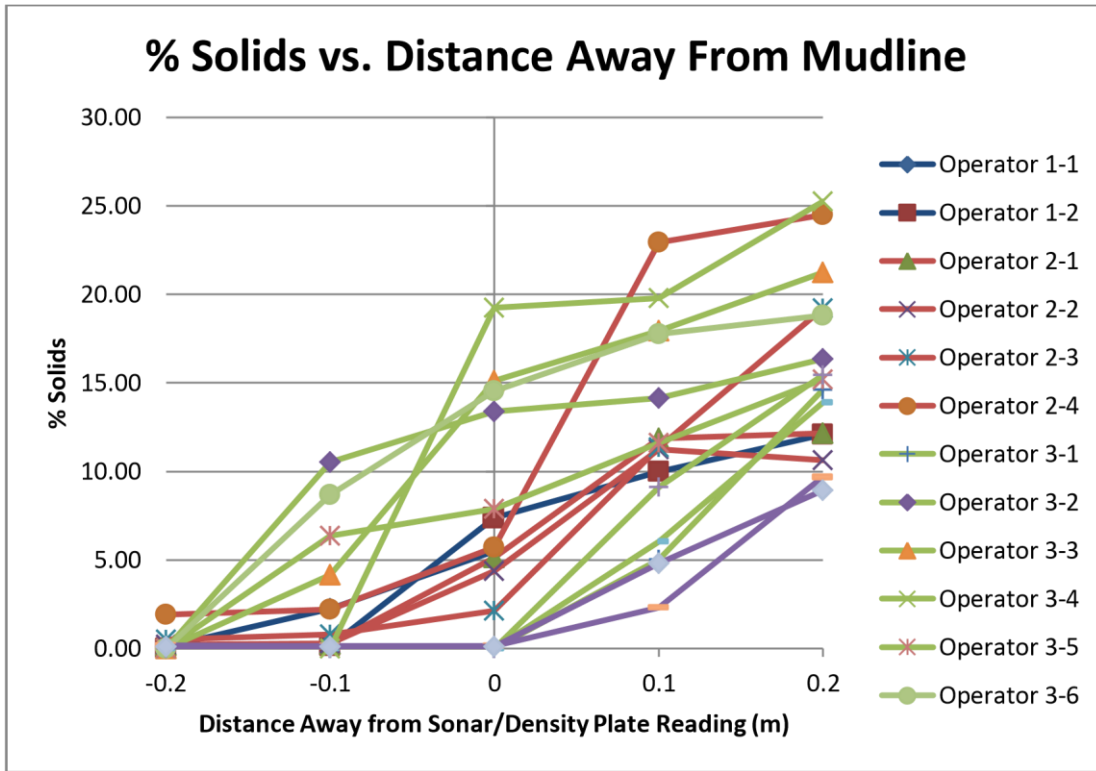

APPENDIX C: VALIDATION OF BOTTOM OF POND

Cone Penetration Tests (CPT) to verify the bottom of pond measured with the CT09

Guidelines for Tailings Deposit Sampling and Measuring Tools

To validate that the drop sounding tool (CT09) is accurately measuring the true bottom of pond, some periodic CPTs are required to validate the measurements. Bottom of pond measurements with the drop sounding tool CT09 and the CPT for tailings deposits of coarse tailings and CT show good correlation and are shown in the plots below. The CPT is the recommended method to validate the elevation determined by the CT09. If CPTs are used to determine the bottom of pond elevation, no validation is required however the interpretation needs to be done by experienced personnel.

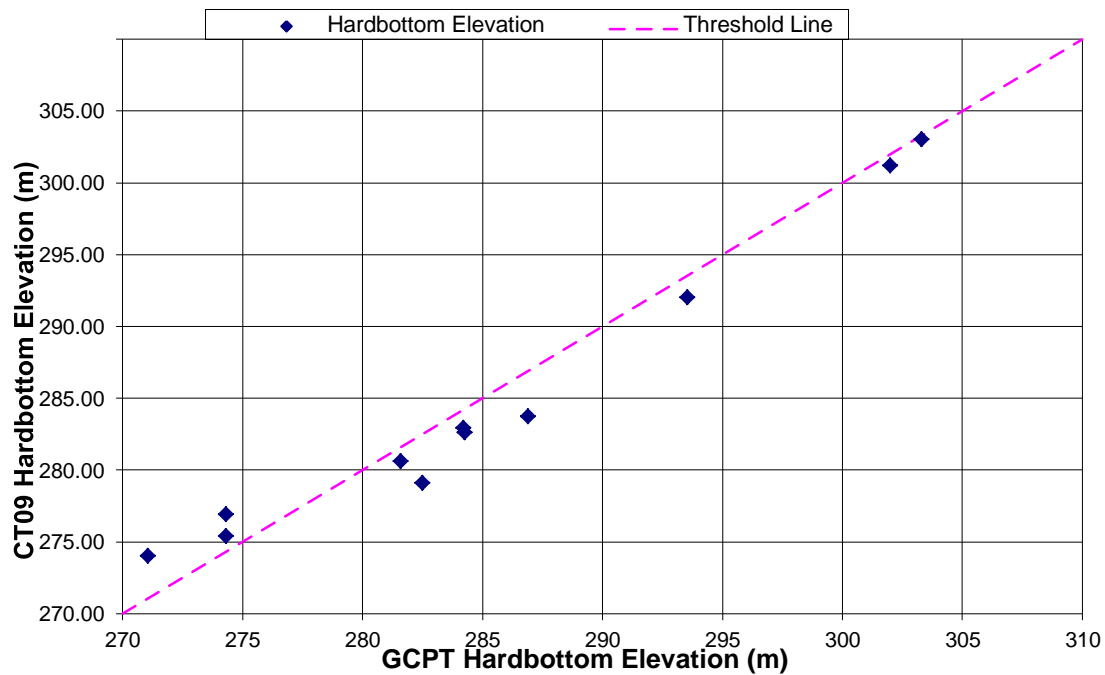

310.00

Operator

Operator 1(Conventional Tailings Pond) Drop Sounding Tool vs.

Guidelines for Tailings Deposit Sampling and Measuring Tools

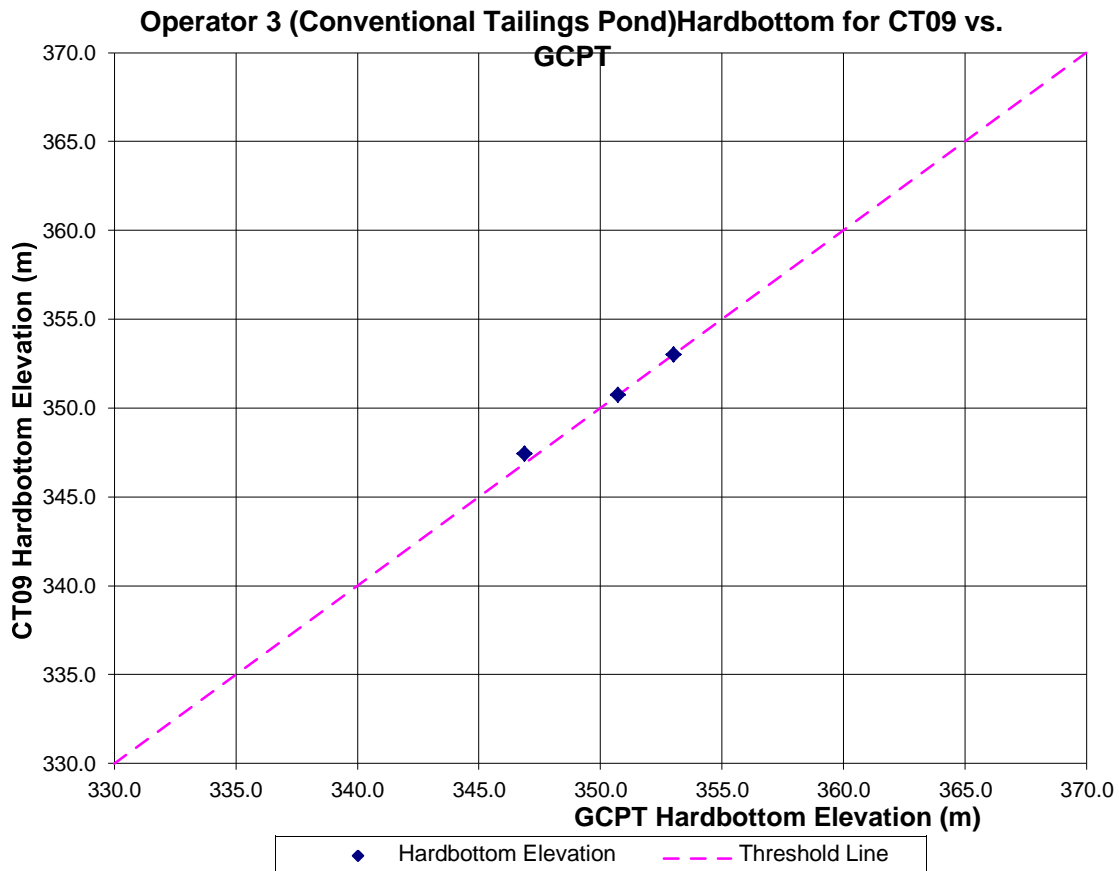
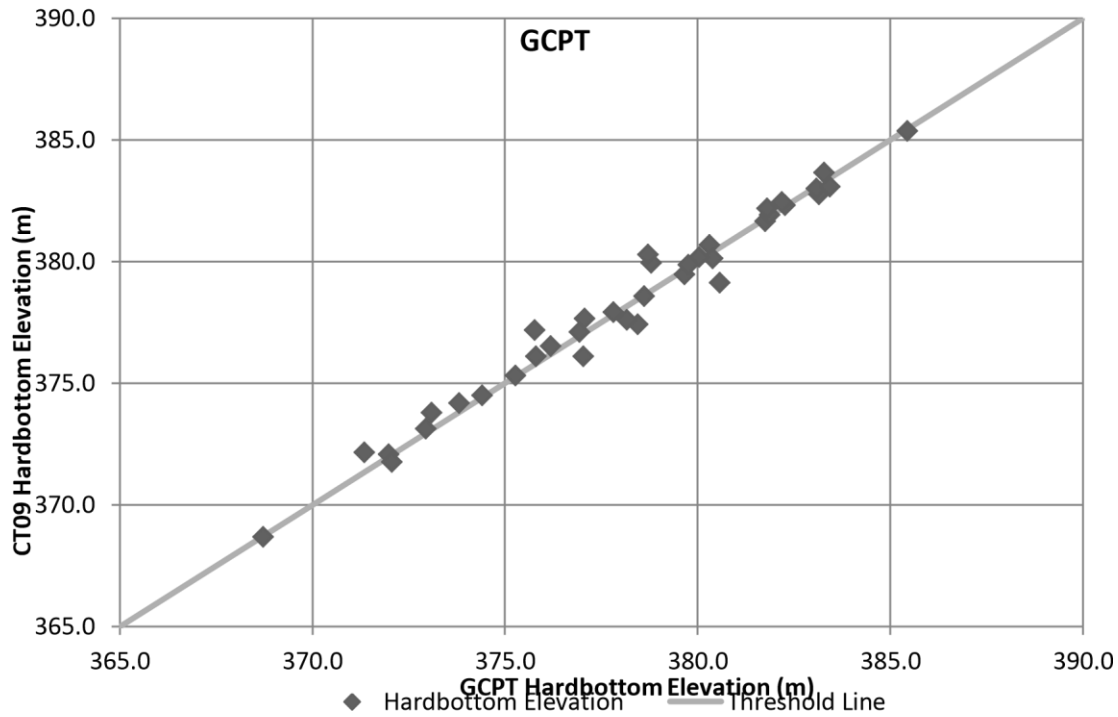

Solid content as an identifier to verify the bottom of pond measured with the CT09

Guidelines for Tailings Deposit Sampling and Measuring Tools

A common solids content was suggested as an identifier for validating the elevation interpreted from the CT09 or the CPT. Graphs of solids content of samples taken at hard bottom refusals are show below. There are difficulties with this verification method for the following reasons:

- The elevation of the samples collected (collected every 1m) often are not at the same elevation as the bottom of pond elevation interpreted from the CT09 or CPT, so there is very limited data to investigate this comparison,
- There is a sharp increase in solids content at the bottom of pond so the solids content of the sample collected could vary considerably, and
- Sampling the bottom of the pond is not typically done nor required.

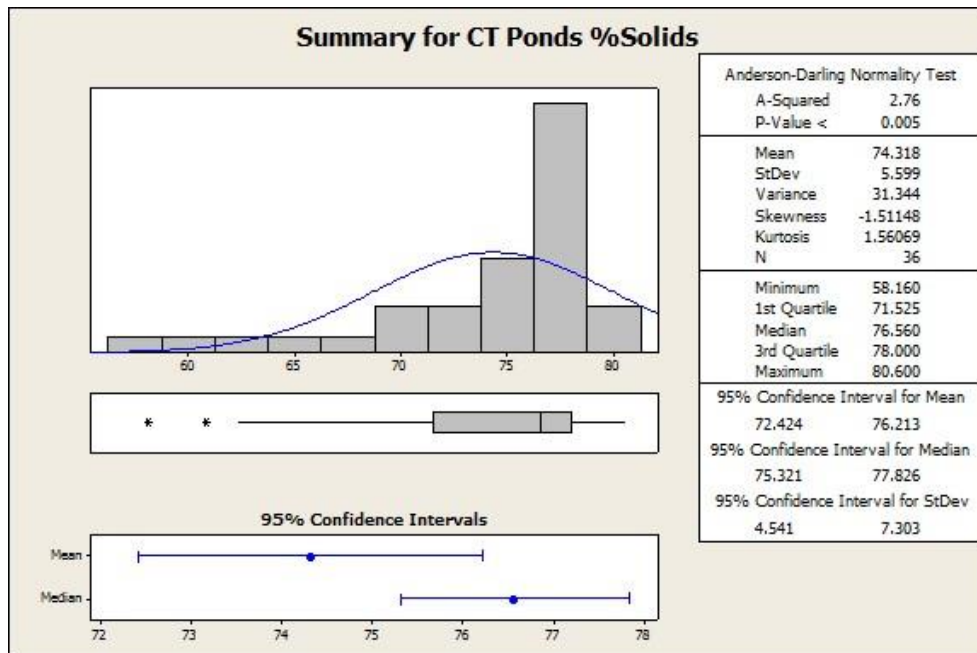
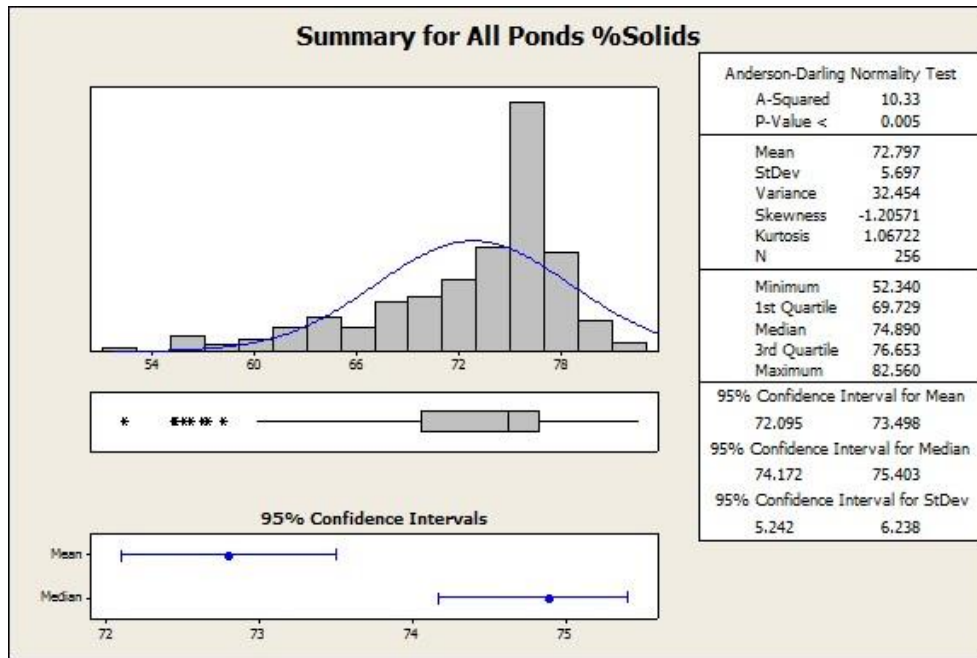

Guidelines for Tailings Deposit Sampling and Measuring Tools

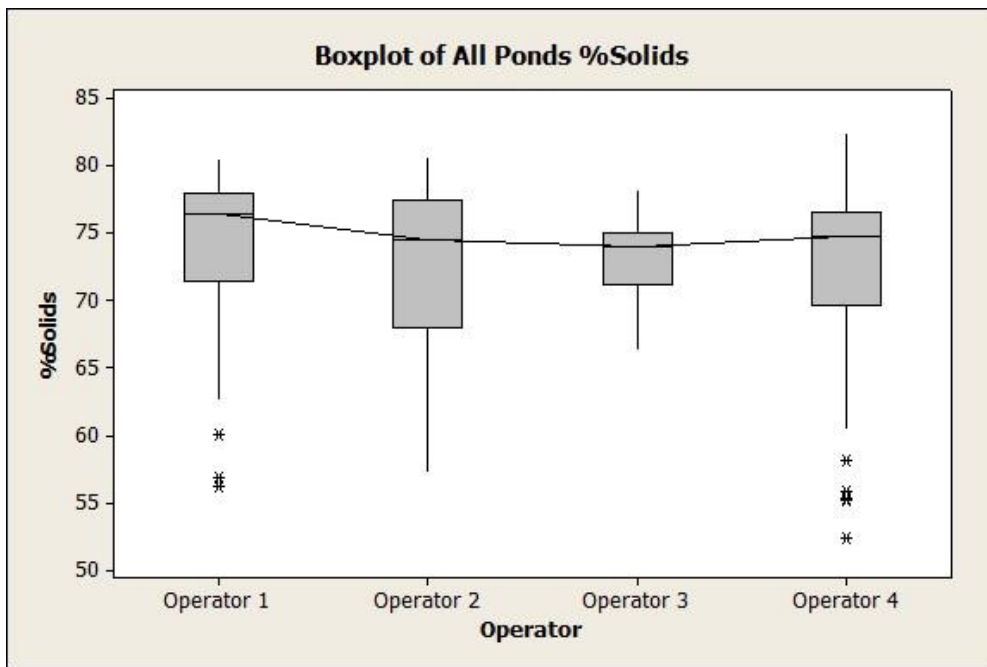
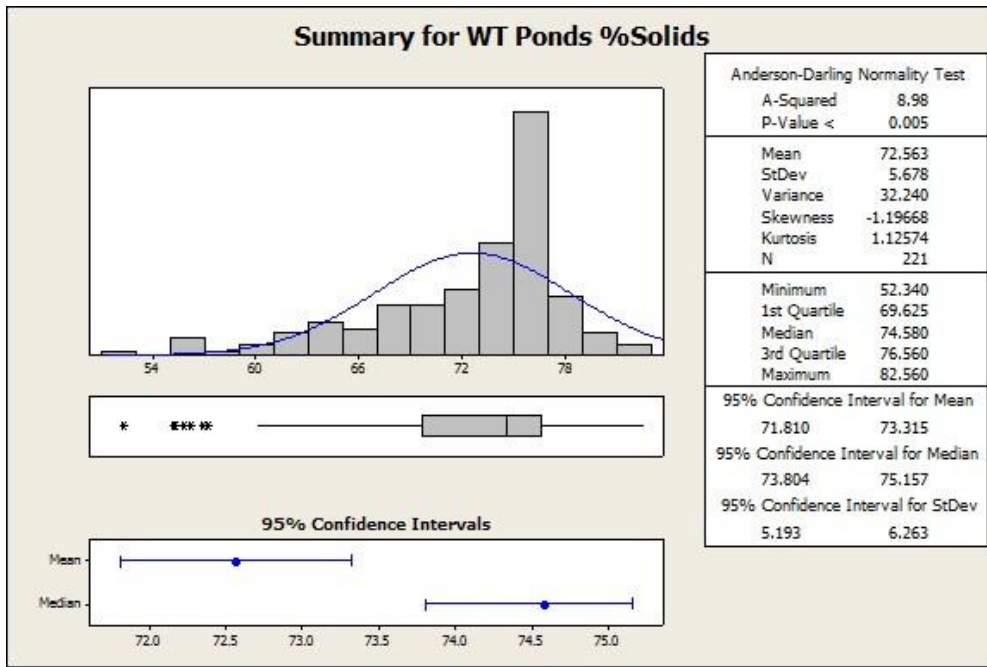

Guidelines for Tailings Deposit Sampling and Measuring Tools

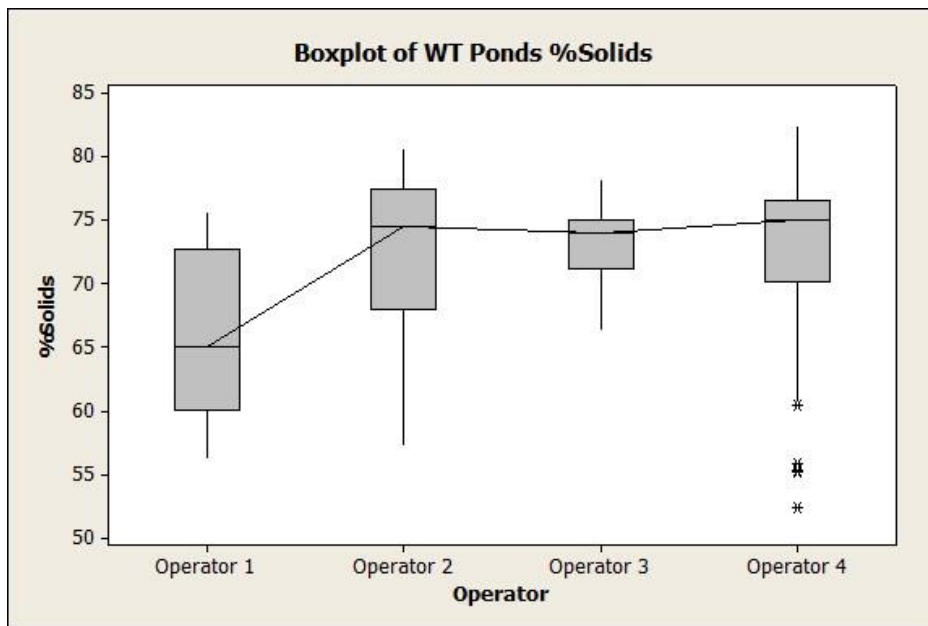
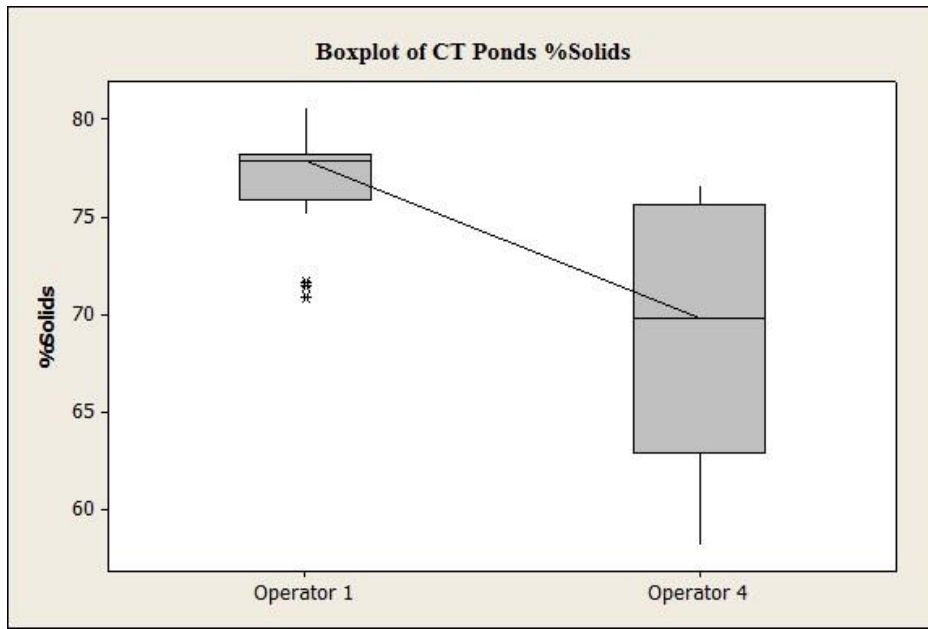

Undrained shear strength as an identifier to verify the bottom of pond measured with the CT09

A common undrained shear strength (greater than or equal to 5 kPa) was suggested as an identifier for validating the elevation interpreted from the CT09 or the CPT. The correct interpretation of the CPT data is required by experienced personnel as it is possible to have denser zones that are greater than 5 kPa much higher than the bottom of pond.

Similar to measuring the solids content, the shear strength typically has a sharp increase at the bottom of pond so the range could vary widely at the elevation identified by the CT09. In addition, the shear strength of the bottom of the pond is typically not tested nor required.

APPENDIX D: COMPARISON BETWEEN PISTON SAMPLERS

There is limited data that compares the various sampling tools for comparative results. There is some data on a comparison between the standard piston sampler and the sonic sampler that uses an AquaLock type piston sampler.

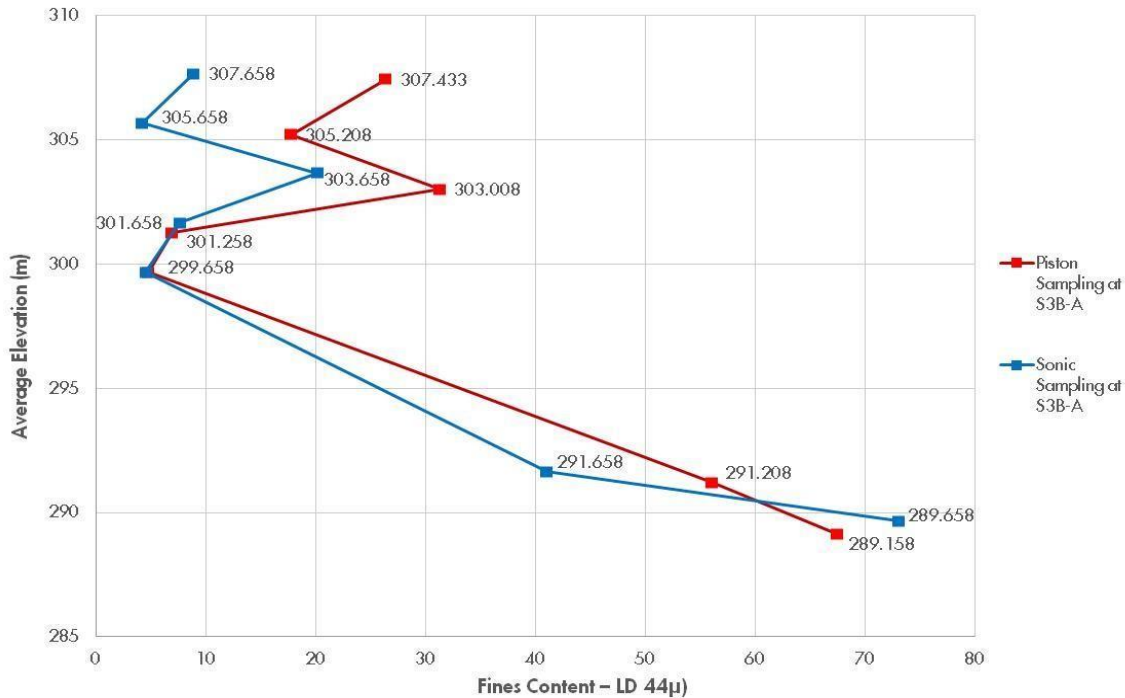

There is still reliability issues related to the liquefaction and the potential to lose water or fines during sampling, and therefore the measured solids or fines content could be affected. The AquaLock piston sampler currently being used visually appears to be capturing the water. This is one area where further testing and research is needed. Presently, the sonic sampler with the AquaLock type thick walled piston sampler is the most efficient production sampler available for oil sands tailings deposits, especially when the deposits are deep or layered or both.

APPENDIX E: SUB-SAMPLING VALIDATION USING DUPLICATE SAMPLES

Sub-sampling into a number of smaller representative samples is required for further characterization tests, such as bitumen, solids and fines content or other chemical tests. The subsampling can be done in the field or in the laboratory.

The graphs show duplicate samples sub sampled from up to a 5 litre bucket from the laboratory from 3 Operators. Data shows that the fines content provide representative samples during the sub sampling procedure.

Operator 1

Guidelines for Tailings Deposit Sampling and Measuring Tools

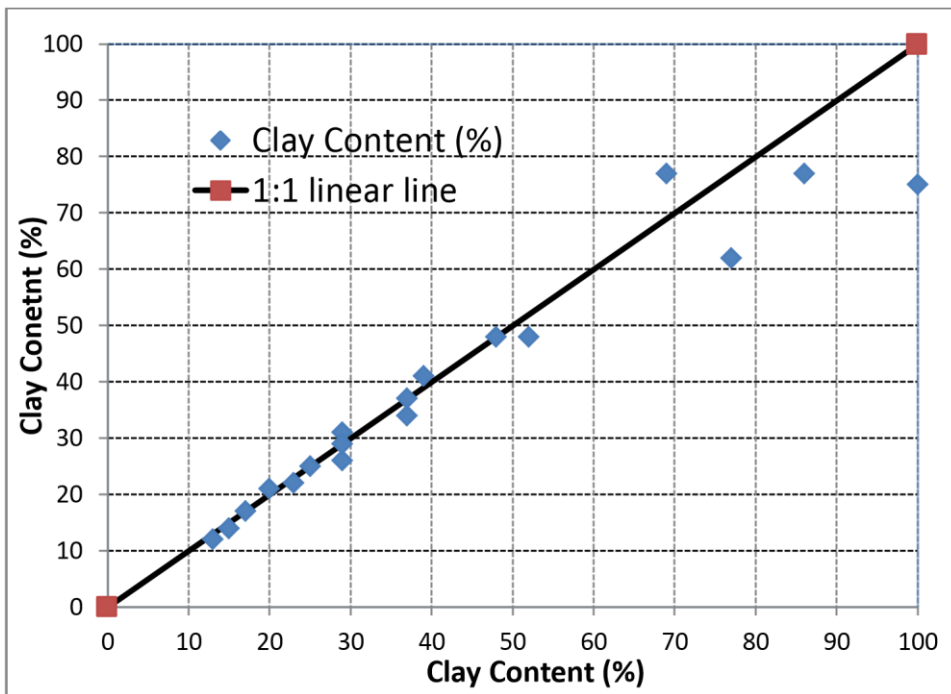
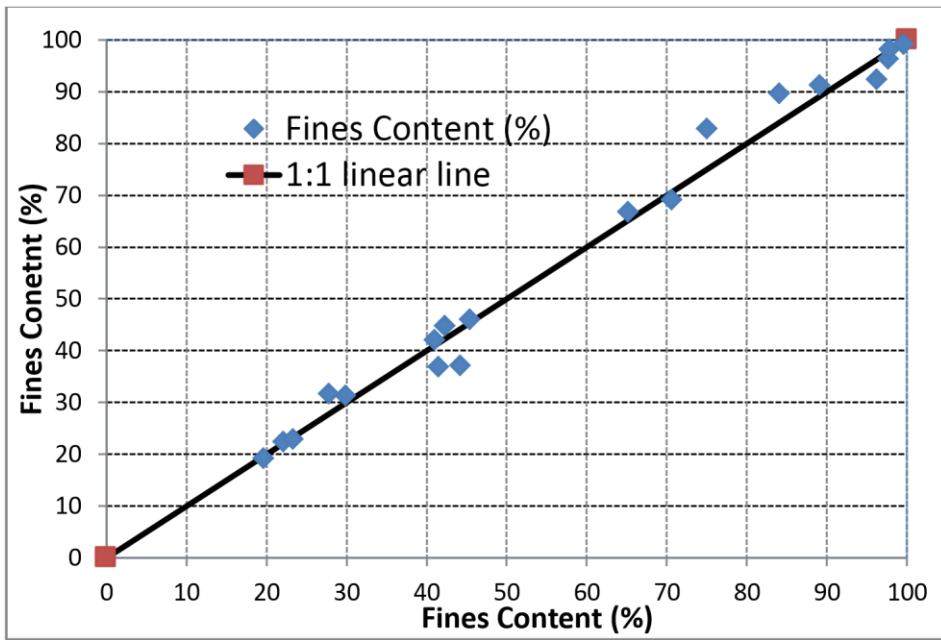

Operator 2

Guidelines for Tailings Deposit Sampling and Measuring Tools

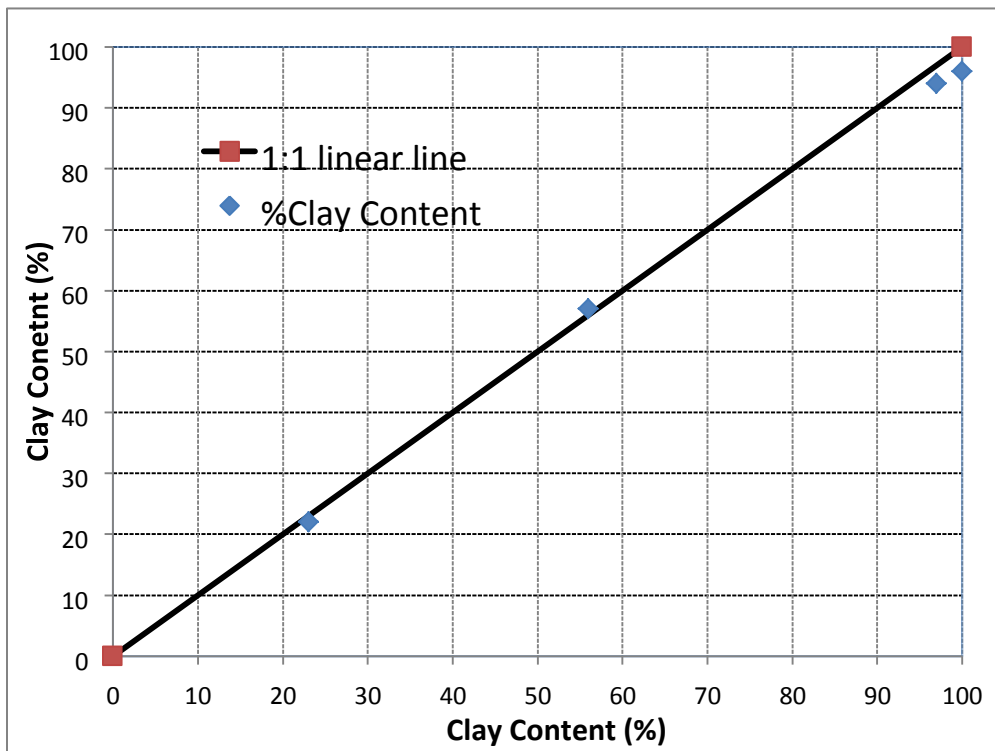
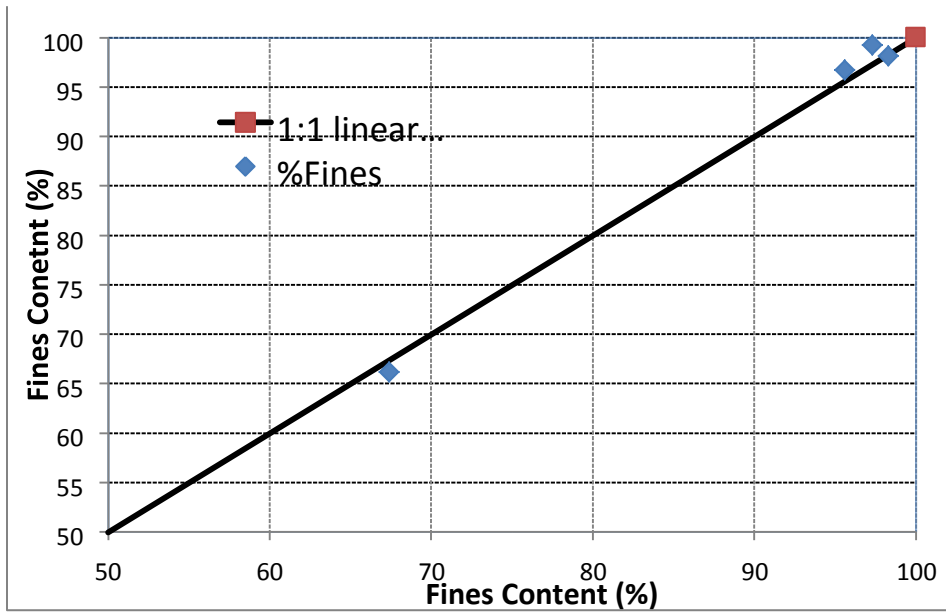

Operator 3

Guidelines for Tailings Deposit Sampling and Measuring Tools

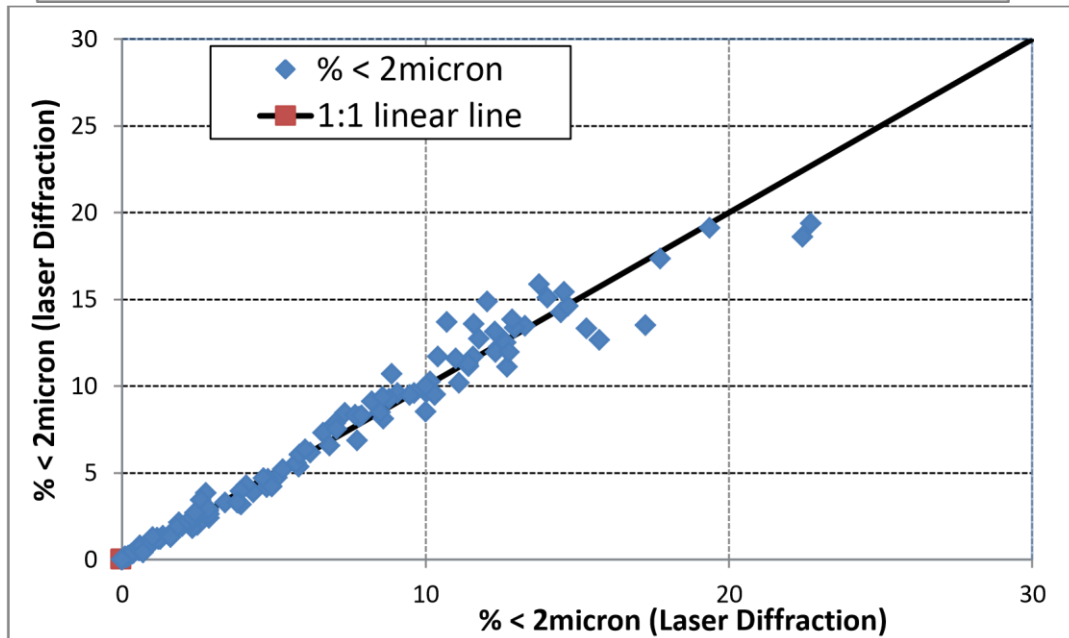
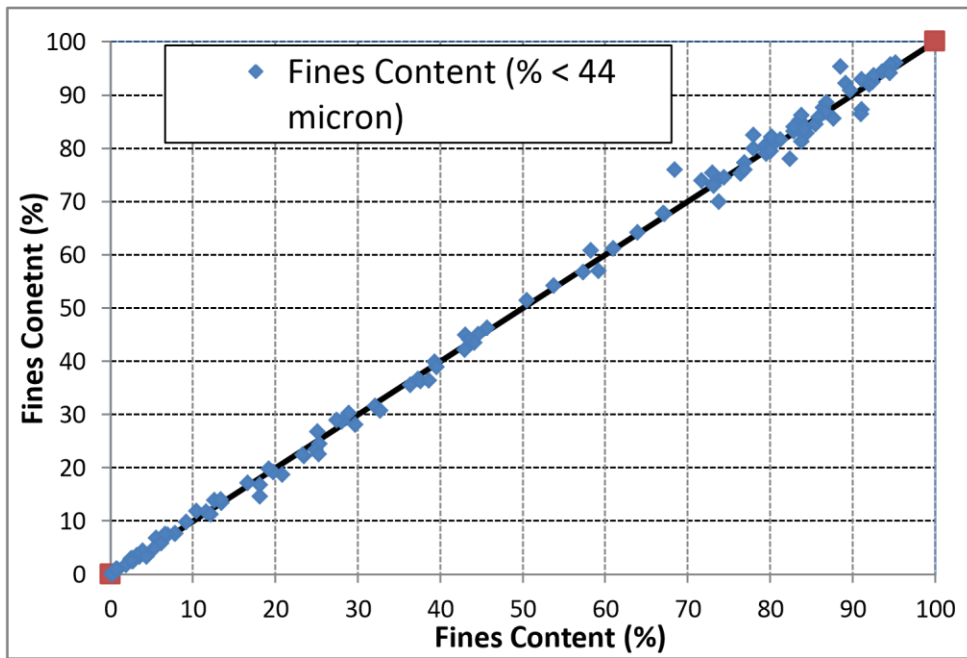

GLOSSARY A: DEFINITIONS AND ACRONYMS

AER	Alberta Energy Regulator
AESRD	Alberta Environment and Sustainable Resource Development
Bitumen Content	Mass of bitumen divided by (mass of solids + water) X100%
Composite/Consolidated Tailings (CT)	Combined mixture of fluid fine tailings or mature fine tailings, sand and coagulant (e.g.; gypsum)
Consolidation	Compression or densification of a soil deposit through a change in the effective stresses, reduction in void space, and expulsion of pore fluids
COSIA	Canada’s Oil Sands Innovation Alliance
Dedicated Disposal Area (DDA)	Defined in Directive 074; “...an area dedicated... to the deposition of captured fines using a technology or suite of technologies...”
Drained Shear Strength	Measured shear strength when shear stress is applied at a sufficiently slow rate and the drainage boundary conditions are such that excess pore pressure is zero when the failure occurs
Fines Content (FC) or percent fines	Mass of fines divided by mass of mineral solids

Guidelines for Tailings Deposit Sampling and Measuring Tools

Fines, fine solids	Mineral solids with particle sizes equal to or less than 44 μm
Fines/(fines + water) ratio (FOFW)	Mass of fines divided by (mass of fines + water) X 100%
Fluid Fine Tailings (FFT)	A liquid suspension of fine tailings or fines-dominated tailings in water, with a solids content greater than 2% but less than the solids content corresponding to the liquid limit. In the context of this report the term “Fluid Tailings” is used synonymously with “Fluid Fine Tailings”.
Geotechnical fines content	Mass of fines divided by mass of solids X 100%
Geotechnical water content	Mass of water divided by mas of solids X 100%
Liquid Limit	The geotechnical water content defining the boundary between a liquid and solid in soil mechanics. This state is defined by a standard laboratory
	test (ASRM D4318-10; modified for use in oil sands tailings containing bitumen). It can also be described in terms of an equivalent FOFW or solids content. This test results in equivalent remoulded shear strength of 1 to 2 kPa.
L	Liter
m	Metre
μm	Microns or micrometres (1×10^{-6} metres)
mm	Millimetres
Mature Fine Tails (MFT)	A subset of FFT with SFR less than 1 and solids content greater than 30%, nominal
Mineral solids	Fines and sand
Non-segregating Tailings (NST)	Tailings that form a homogeneous mass upon deposition (i.e.; tailings that do not have coarser particles that separate from the finer particles, which are then carried away in runoff water or are re-deposited in discrete layers or zones with particle size distributions dissimilar to that of the original tailings materials)

Guidelines for Tailings Deposit Sampling and Measuring Tools

Pa or kPa	Pascals or kilopascals
Plastic Limit	The geotechnical water content defining the boundary between a plastic (i.e.; remouldable) solid and brittle solid in soil mechanics. This state is defined by a standard laboratory test (ASRM D4318-10; modified for use in oil sands tailings containing bitumen). It can also be described in terms of an equivalent FOFW or solids content. This test results in equivalent remoulded shear strength of about 100 kPa.
Sand	Mineral solids with particle size greater than 44 µm and less than 2 mm (does not include bitumen)
Sand to Fines Ratio (SFR)	The mass ratio of sand to fines; the mass of mineral solids with a particle size greater than 44 µm divided by the mass of mineral solids less than 44 µm
Shear Strength	Shear strength is defined as the maximum or ultimate shear stress that a soil can sustain without undergoing large deformations
Shrinkage limit	The geotechnical water content defining the point at which a soil, on loss of moisture, will experience no further volume reduction. This state is defined by a standard laboratory test (ASRM D4318-10; modified for use in oil sands tailings containing bitumen).
Solids	Sand, clay and other solid mineral particles contained in oil sands tailings (does not include bitumen)
Solids Content (SC) or percent solids	Mass of mineral solids divided by total mass (mineral solids + bitumen + water) x 100%.
Sedimentation	Downward movement of solid particles through a fluid to form a sediment or soil layer at the base of the fluid volume
Settlement	Resulting downward movement of a soil deposit through consolidation or compression within the deposit (often measured on the surface of the deposit)

Guidelines for Tailings Deposit Sampling and Measuring Tools

Tailings	A by-product of the bitumen extraction process composed of water, sand, fines, and residual hydrocarbons
Thin Fine Tailings (TFT)	A subset of FFT with SFR less than 1 and solids content less than 30%, nominal
Thickened Tailings (TT)	Tailings treated through thickeners and in-line flocculation
Undrained Shear Strength	Measured shear strength when the drainage boundary conditions are such that the shear-induced excess pore pressure does not dissipate as the material is strained
UOSTCS	Unified Oil Sands Tailings Classification System
Void Ratio (e)	Volume of Voids divided by volume of solids
Water Content (w)	Mass of water divided by mass of (solids + bitumen + water) X 100%
Whole tailings (WT)	Tailings produced directly from the primary and secondary separation vessels in the extraction plant, containing sand, fines and water from the oil sands ore plus recycle water

Guidelines for Tailings Deposit Sampling and Measuring Tools

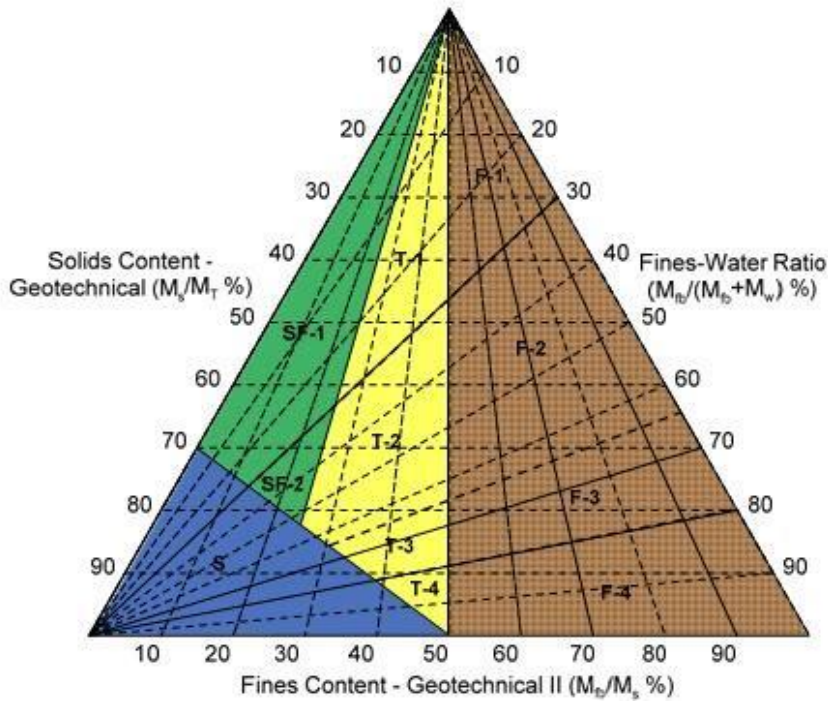

Primary Division		Secondary Division	Symbol	Name
Sand Void Ratio ≤ 1.1		none	S	Sand
Fines Dominated Tailings Sand void ratio > 1.1	Sandy-Fine Tailings SFR ≥ 3 (fines content geotechnical II $\leq 25\%$)	FWR $<$ static segregation boundary	SF-1	Sandy Fine Tailings - Zone 1
		Liquid limit $>$ FWR \geq static segregation boundary	SF-2	Sandy Fine Tailings - Zone 2
	Transition Tailings $3 >$ SFR > 1 (25% $<$ fines content geotechnical II $<$ 50%)	FWR $<$ static segregation boundary	T-1	Transition Zone 1
		Liquid limit $>$ FWR \geq static segregation boundary	T-2	Transition Zone 2
		Plastic limit $>$ FWR \geq liquid limit	T-3	Transition Zone 3
		FWR \geq plastic limit	T-4	Transition Zone 4
	Fine Tailings SFR ≤ 1 (fines content geotechnical II $\geq 50\%$)	FWR $<$ static segregation boundary	F-1	Fine Tailings Zone 1
		Liquid limit $>$ FWR \geq static segregation boundary	F-2	Fine Tailings Zone 2
		Plastic limit $>$ FWR \geq liquid limit	F-3	Fine Tailings Zone 3
		FWR \geq plastic limit	F-4	Fine Tailings Zone 4

Guidelines for Tailings Deposit Sampling and Measuring Tools